

Instructions

Gryphon Diamond Wire Saw model Omni-1

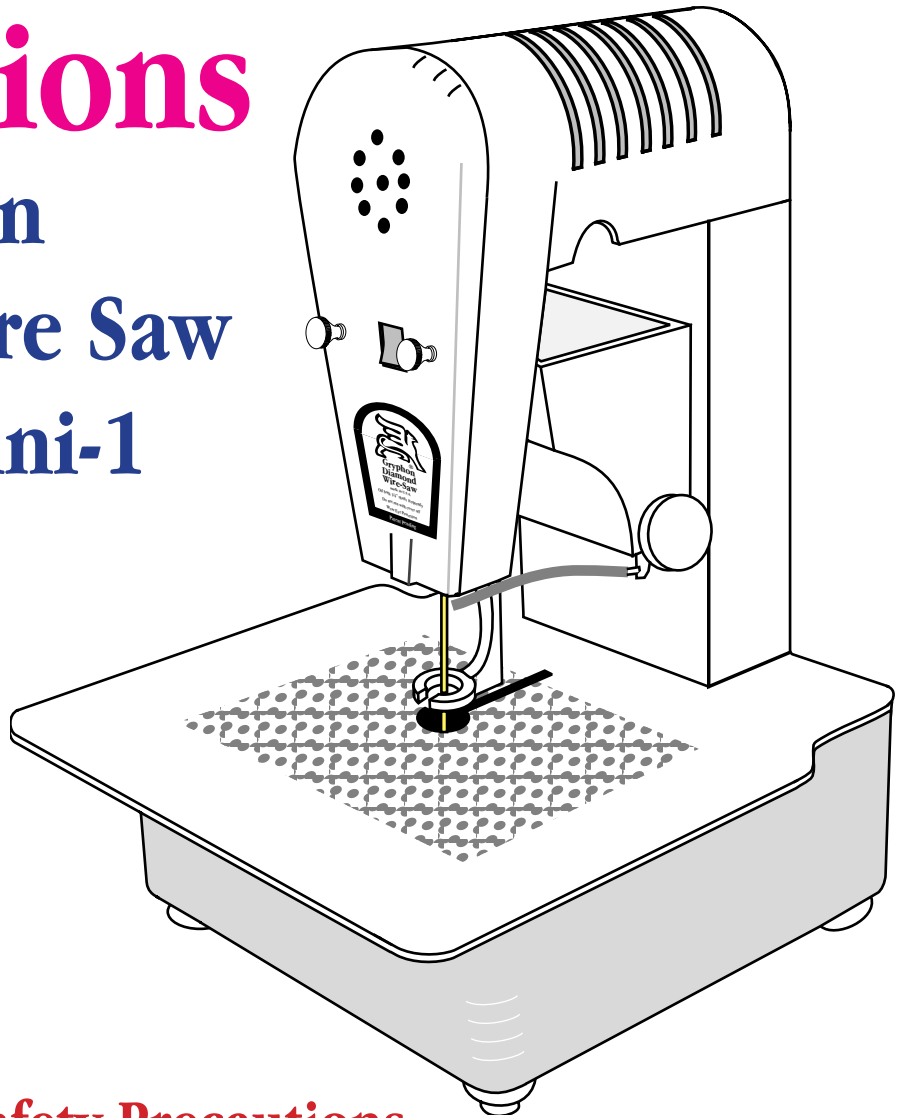

Safety Precautions

- Always wear eye protection •
- Do not run blade dry •
- Keep fingers clear of moving parts •
- Do not operate with finger guard removed •
- Do not operate with front cover removed •

Warranty

Your new Gryphon Diamond Wire Saw is warranted for one year from date of purchase. All mechanical parts with the exception of the blade and blade guides are guaranteed against failure for one year. If such a failure occurs for any reason other than abuse or misuse during this period, it will be repaired (or at our option replaced) free of charge FOB our factory. Retain your sales receipt for proof of purchase. Should repairs ever be required, return the saw to Gryphon Corporation.

© 1999 Gryphon Corporation

12417 Foothill Blvd. • Sylmar • California • 91342 • (818) 890-7770

www.gryphoncorp.com

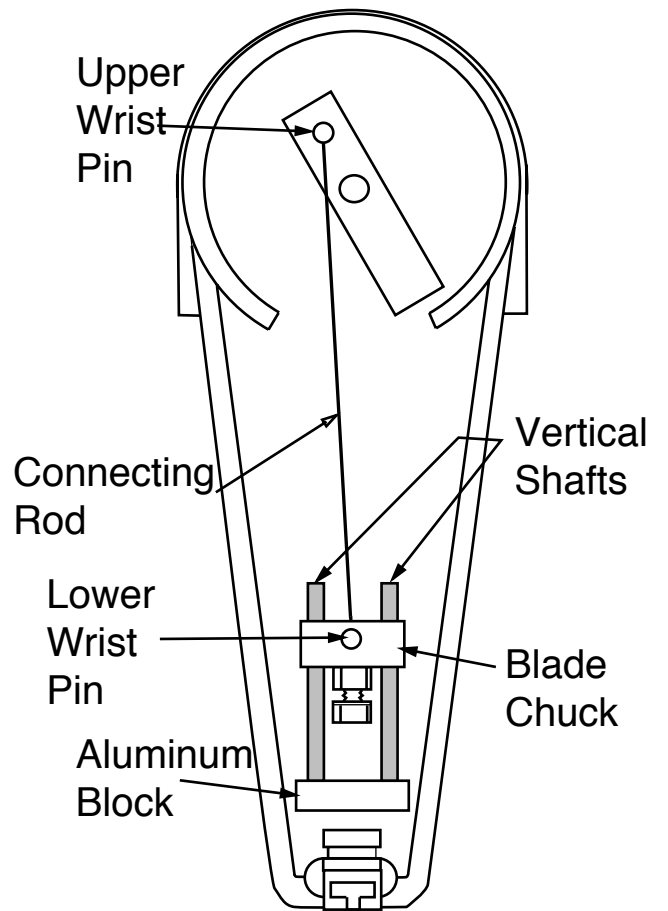
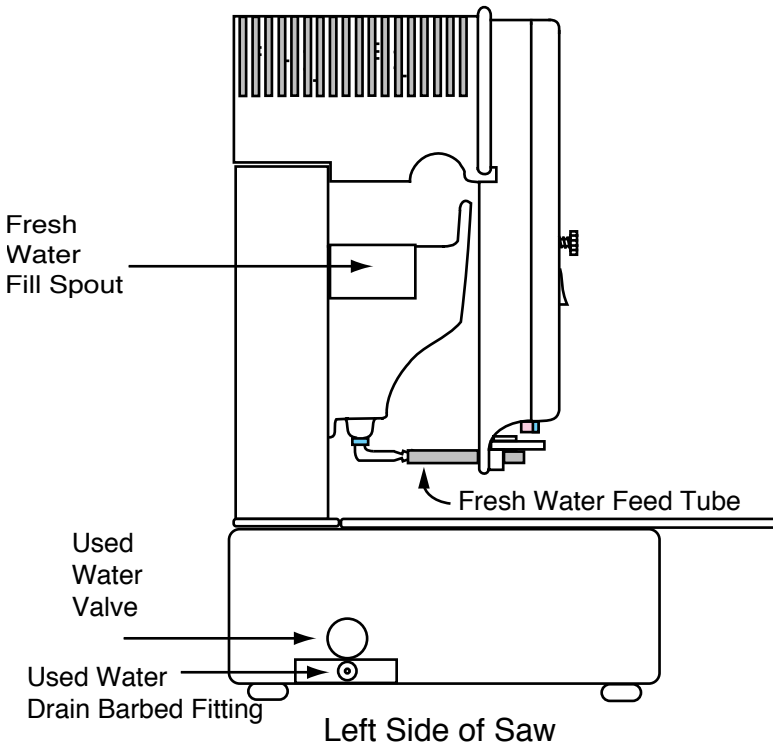
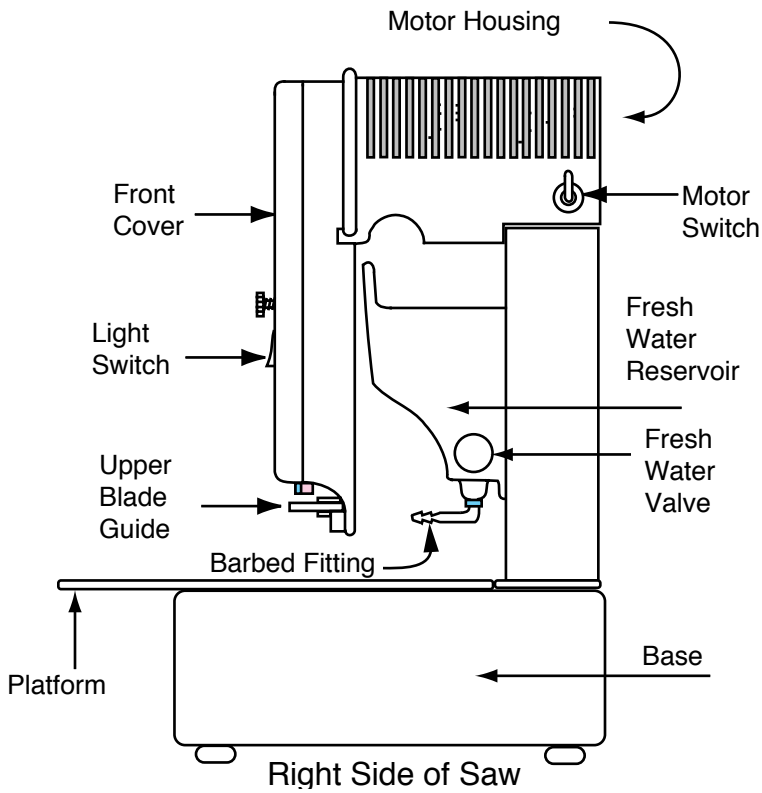

Gryphon Wire Saw Parts Identification

Assembly Step 1

Turn the base of your saw upside down. Push the long piece of tubing from your parts bag onto the barbed fitting. Tubing inside diameters vary widely from batch to batch and from manufacturer to manufacturer. Soaking one end of your tubing in hot water helps to overcome a too-tight fit.

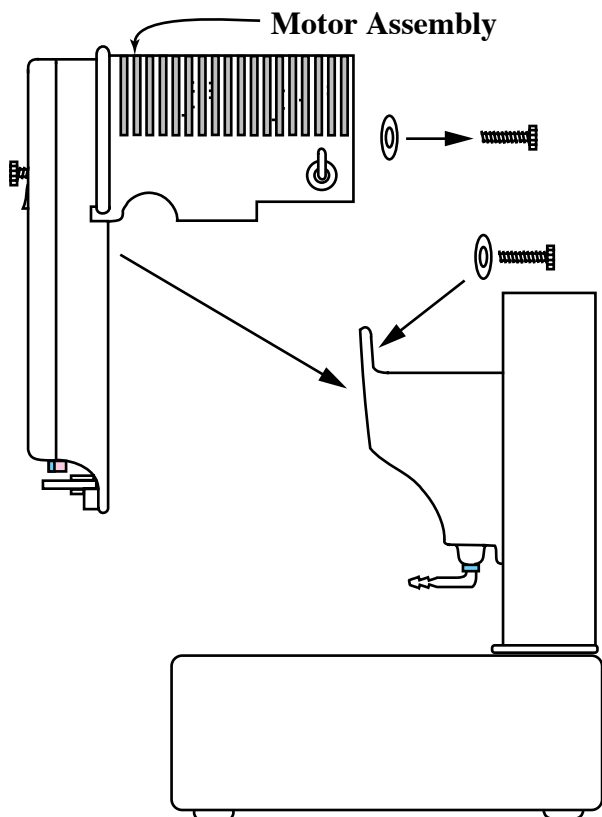
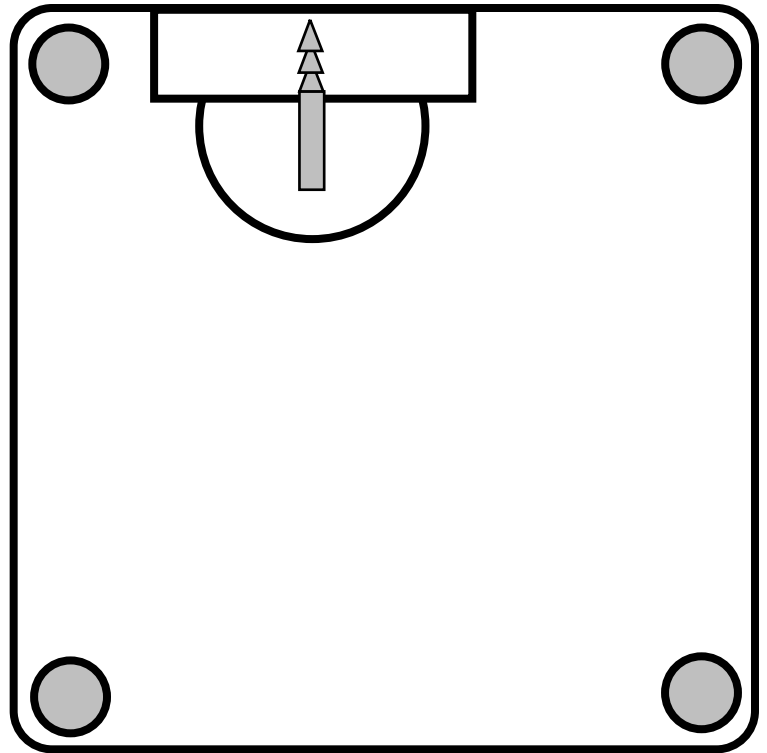

Assembly Step 2

Place motor assembly on top of base. Slip a plastic washer onto each of the two plastic thumbscrews found in your parts bag. Insert thumbscrews into blue grommets at the upper outside corners of the water tray. Tighten screws into motor assembly snug tight only.

Assembly Step 3

Push the short piece of tubing from your parts bag onto the barbed fitting at the bottom of your water tray.

Thread the other end of the tubing through the hole just below the blade guide.

Take the finger guard from your parts bag and push it into the “T” shaped slot at the bottom of the motor assembly.

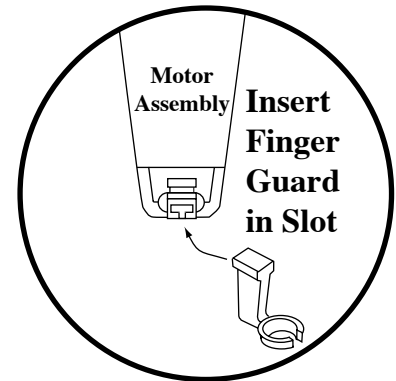
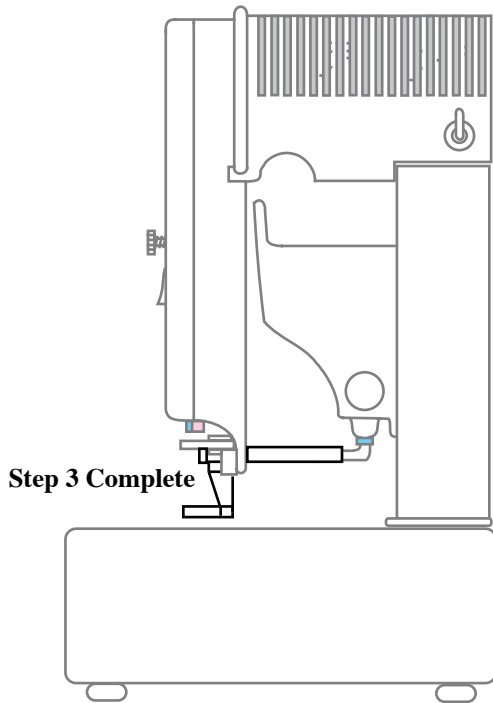
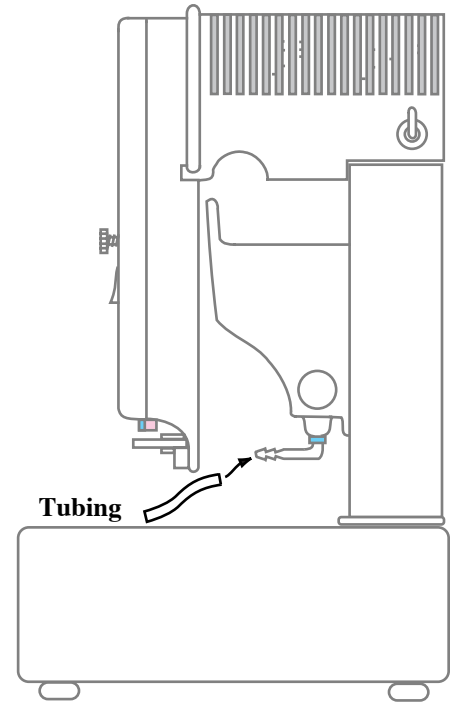

Assembly Step 4

Installing your first Blade:

Remove the two nylon screws from the Front Cover and lift off the Front Cover.

The Rotor may stop in any position (A). Turn the Rotor by hand until the Blade Chuck is in its lowest position (B). (Note: it is not necessary to remove the Front Cover when changing blades. Just pull down on the old blade until the nut appears).

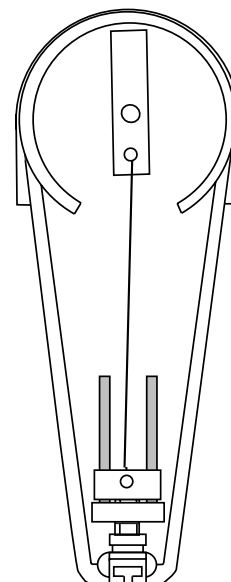
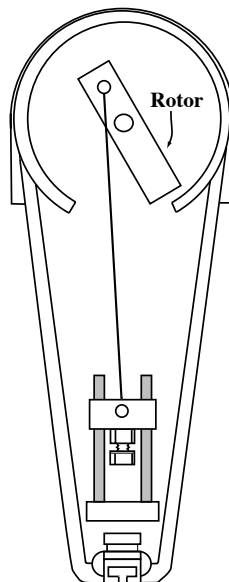

Remove the bottom guide by pulling forward on the guide. Drop the unpainted end of a new blade into the bottom guide hole (C).

Thread the top painted end of the blade into the hole in the top guide (D). Continue pushing the blade up into the blade chuck until it stops. Tighten the 7/16" nut snugly with the provided wrench. Replace the bottom guide. To remove a worn blade reverse this process.

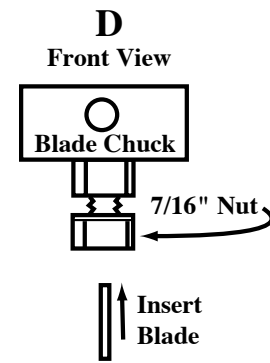
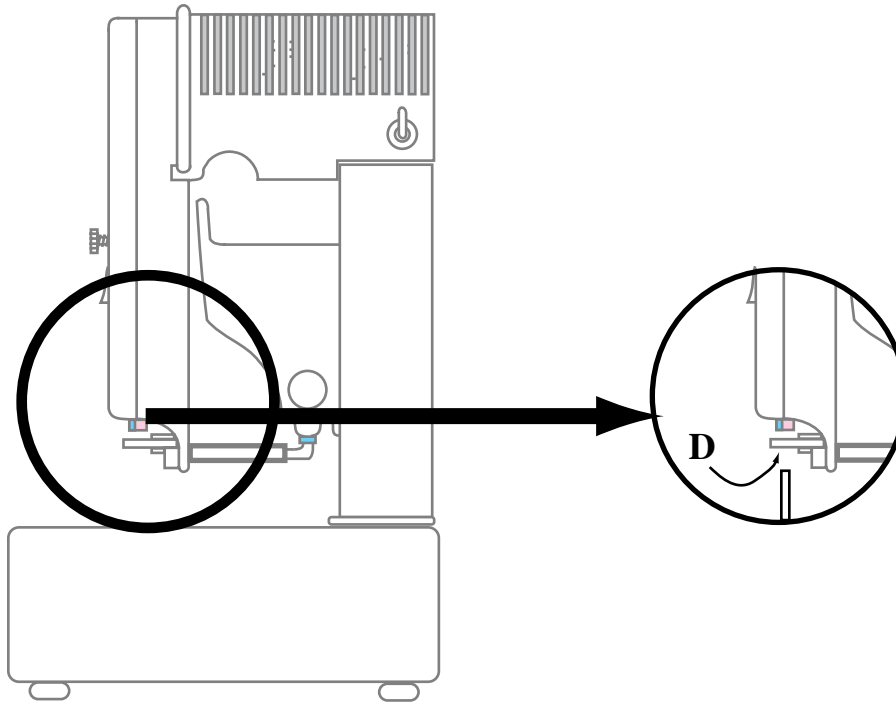
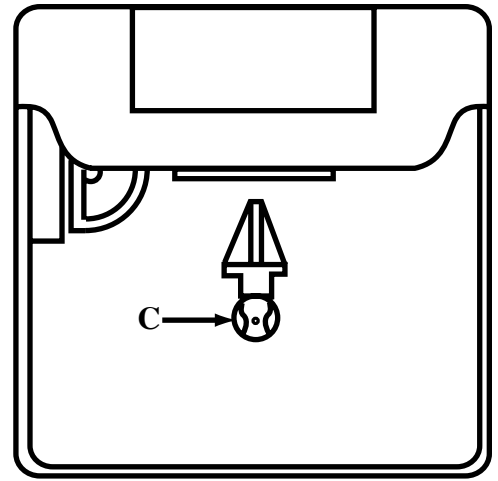

Assembly Step 5

Turn the Front Cover face down. Remove the four screws that secure the Battery Holder Lid. Lift off the Battery Holder Lid.

Install two AA flashlight batteries (not included) into the battery holder. Be careful to follow the polarity shown on the battery holder. Turn the switch on. If the lamp does not light, one or both of your batteries may be installed backwards.

Re-install the Battery Holder Lid. Start screws by twisting counter-clockwise until you feel the threads drop into place. Then twist the screws clockwise until they are snug tight. Over tightening will strip the treads. Never operate the saw with the Battery Holder Lid removed, as the batteries may fall into the mechanism.

Re-install the Front Cover and tighten the two plastic screws which you removed earlier.

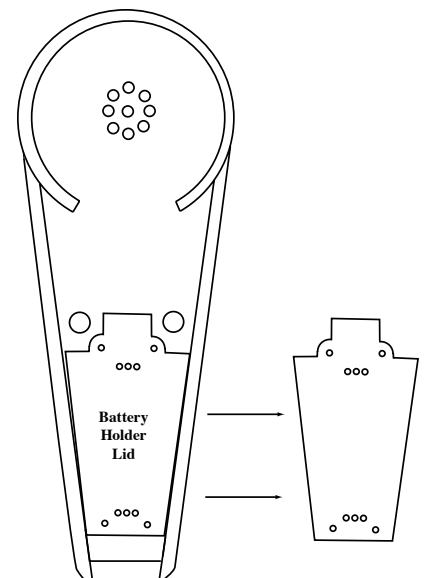

Preparing to Saw

Place a container on the floor. Put the end of your long drain hose into the container.

Important: Fill the base up to the overflow with water. The water provides cooling for the blade and extends guide life.

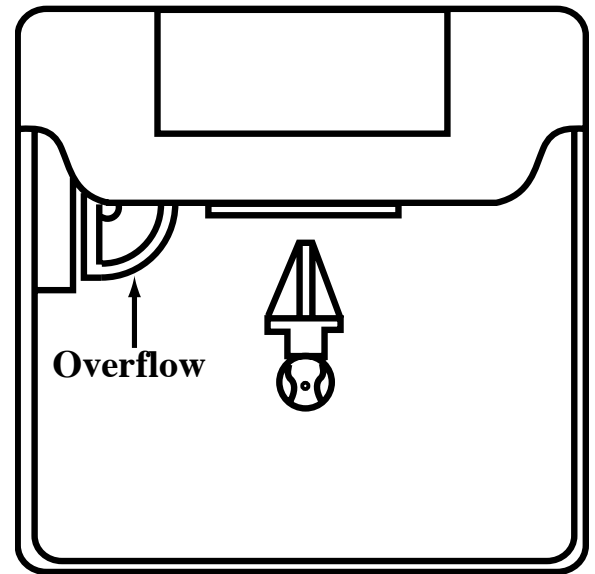

Unscrew the water tray screw until water begins to flow onto the blade. Unscrewing further increases the water flow.

Fill the water tray 3/4 full with water

Used water valve

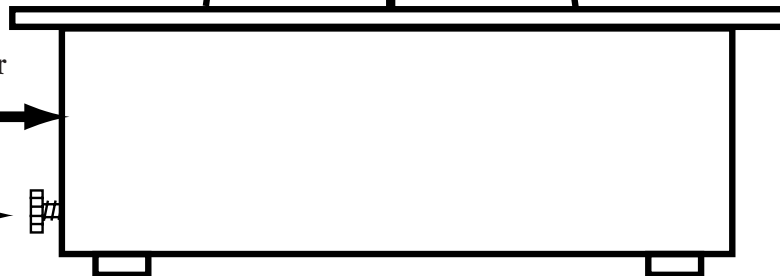

Wear eye protection. Turn the switch on and you may begin sawing. You may push the glass in any direction.

When sawing is finished, screw in the water tray screw until water no longer flows onto the blade.

At the end of the day, you can drain the water in the base by unscrewing the base screw until water begins to flow through the long hose into the container on the floor.

Start up Maintenance

It is necessary to keep the two steel vertical shafts lubricated with light oil. If your shafts do not feel oily to the touch, wipe “3-in-1” oil or light motor oil on them with your fingers. Do not use vegetable oil. Do not use spray lubricants.

These shafts are ground to micro finish in order to make your blade chuck last a long time. If you allow your shafts to rust or become dry you will drastically reduce the blade chuck life.

Sawing

Put on eye protection. Start the water flow to the blade. The water feed hose should touch the blade. Turn the switch on and saw in any direction.

Pulling the glass towards you pulls the blade away from the water feed and may make it difficult to see your pattern line. If this happens, increase the water flow by unscrewing the water tray feed screw a little more.

As you near the end of your cut, ease off on the pressure you apply to the glass to minimize risk of breakage.

Stretching our \$\$\$\$

Most cuts will be done by pushing away from you and from side-to-side. This will dull the diamond on the blade front and sides, but leave the back relatively sharp. By loosening the Blade Chuck’s 7/16” nut and turning the blade 180 degrees, you can extend your useful blade life.

Note that the blade should never be installed upside-down. To do so will drastically shorten your guide and Blade Chuck life.

Just like a band saw, or any other diamond tool, these blades will become dull from use and you will have to push harder to make cuts. Pushing extremely hard can break your blade. Finally the blade will need to be replaced. The beauty of the Gryphon Wire Saw is that the blades are inexpensive. 15 of the Wire Saw blades cost the same as one band saw blade, but 15 Wire Saw blades will cut nearly twice as much glass under normal use as one band saw blade.

Replacement blades are offered in a choice of three grits. The Standard blade is the finest grit, and offers the smoothest finish. It is recommended for delicate glass, and where the quality of the edge is important.

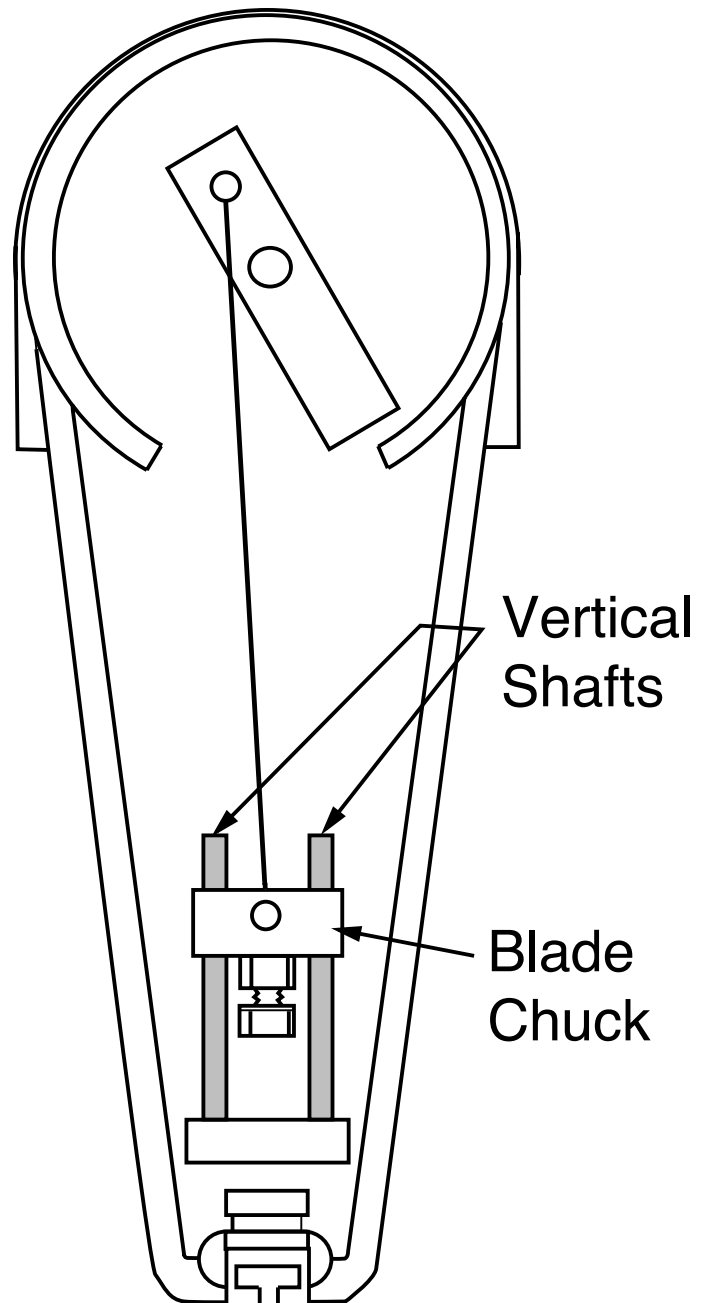

The Super Power blade has the largest diamond particles, and cuts the fastest. It is recommended for difficult glass, tile and stone, or where speed is important. This blade also has the longest life.

The Power blade offers a compromise between the Standard and Super Power blades.

Changing parts

Blade guides pull straight out toward the saw front. They snap in place, so expect a little resistance when removing and replacing them. Replace the guides when the blade hole becomes sloppy. Note that the upper and lower blade guides are not interchangeable.

If the blade chuck wears from use the saw will become quite loud when running. To change:

1. Remove blade.
2. Loosen set screw in upper wrist pin.
3. Slide connecting rod out of upper wrist pin.
4. Pull connecting rod and blade chuck up and out of saw.
5. Loosen set screw in lower wrist pin and pull out connecting rod.
6. Put the wrist pin into a new blade chuck.
7. Push connecting rod into lower wrist pin hole until it stops, then tighten set screw.
8. Replace assembly onto the two vertical shafts and thread connecting rod into the upper wrist pin.
9. Turn the rotor to down position as shown in the diagram to the right.
10. Insert the thin (gauge) end of your chuck wrench between the top of the aluminum block and the blade chuck.
11. Push the blade chuck downward until the chuck wrench is held snugly.
12. Tighten the set screw on the upper wrist pin and remove the chuck wrench. Oil both vertical shafts to complete the replacement.

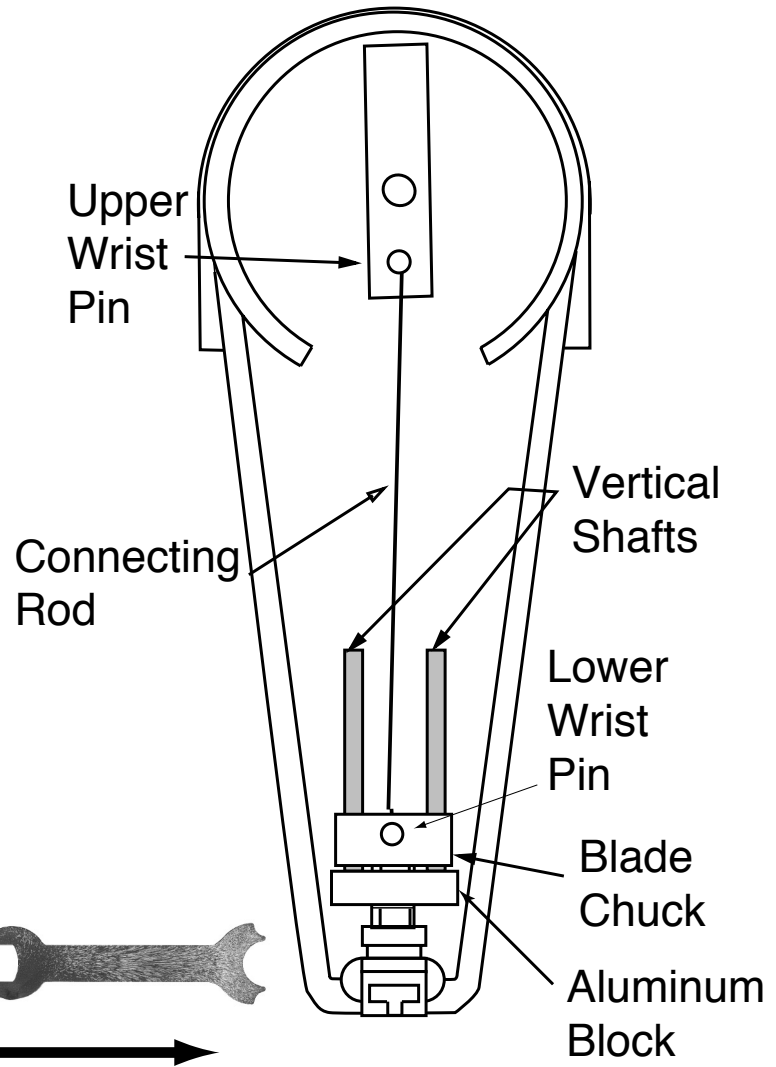
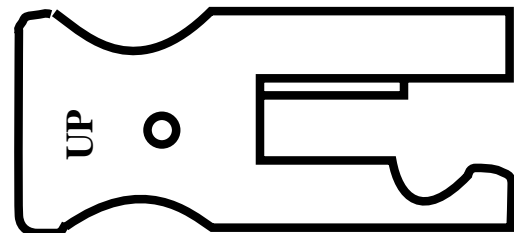
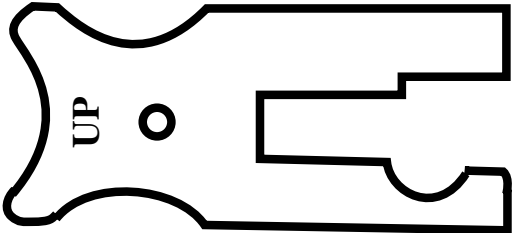

Unclogging the drain line

Usually wiping the end of the drain line and blowing into it will clear debris from the passage. Occasionally you may need to remove the barbed fitting and clean it with a needle.

